

Plusrite®



LED STREET LIGHT

LD331

LD331 LED STREET LIGHT



DESCRIPTION

Plusrite LD331 comes with advanced die-cast aluminum housing with contemporary design, outstanding heat dissipation design to enhance great and stable lifetime, brilliant performance to match the urban and residential demand.



SPECIFICATIONS



Model No.	LD331/50W/7XX	LD331/100W/7XX	LD331/150W/7XX
Wattage (W)	30-60	80-120	130-200
Voltage (V)	100-277		
CRI	70		
Efficacy (LM/W)	160		
Output (LM)	4800-9600	12800-19200	20800-32000
Lifetime (Hours)	L70B50: 50,000Hours @ 25 C /77°F		
CCT	3000K/4000K/5000K		
Beam Angle (°)	Type I/II/III Long/Medium/Short		
Housing Material	Die-casting Aluminum PC/PMMA lens		
Mast Spigot	60/76mm and 42/60mm		
Dimming	0-10V		
Surge Protection	6KV		
IK Degree	IK09		
IP Degree	IP66		
Operation Temperature	-40~50°C (-40°F~122°F)		
Warranty	5 Years		
Dimension	560*275*105cm (8.07*5.98*6.65inch)	610*275*105cm (8.07*5.98*6.65inch)	690*330*105mm (10.83*5.98*6.65inch)
Optional Function	MW or PIR Control/NEMA Base/Zhaga Socket		
Mounting	Side-entry/Post-top/On mast		

KEY FEATURES

- Excellent design with efficacy 160lm/W which can significantly reduce energy consumption.
- Compact, light weight and smart design of complete separation chamber for LED board and driver to get better thermal management, minimum luminous flux degradation and reliable operations.
- Extended long service life of up to 100,000 hours thanks to optical heat dissipation via ribs-free cooling design.
- Robust structure with IP66 protection rating and vibration stability.
- ESD-protected plug & play modules for simple maintenance and low maintenance costs.
- Elegant backside with ribs-free design to avoid dust stratification for easy maintenance.
- Superior optical performance and control with various optic selection.
- Optional International Tier 1 Branded High-Power LEDs.
- Optional International Tier 1 Branded DALI 2 ECG.

STRUCTURE



PACKING

Model No.	n.w. (1 pc)		QTY/ CTN	N.W. (1 CTN)		G.W. (1 CTN)		Carton Dimensions (mm)	CBM (M ³)	QTY/20GP	QTY/40HQ
	kgs	lbs		kgs	lbs	kgs	lbs				
LD331/50W	5.10	11.22	1	5.10	11.22	5.60	12.32	600*300*165	0.0297	940	2160
LD331/100W	5.80	12.76	1	5.80	12.76	6.40	14.08	650*300*165	0.0322	870	1990
LD331/150W	7.30	16.06	1	7.30	16.06	8.00	17.60	730*360*165	0.0434	650	1480

LD331 LED STREET LIGHT

Plusrite®

TECHNICAL SPECIFICATION



IK09

Impact Resistance:
Tempered Glass



High Lumen:
Up to 32000lm



Corrosion Protection:

Corrosivity Category
C3 (Standard)/C4
(Optional)
According to DIN EN ISO
12944

Lens:

PC/PMMA (Optional)

IP66



Protection Class IEC:
Safety Class I / Class II

Rated Service Life and Warranty:

100,000h (L90/B10) at $T_a = 25^\circ\text{C}$
5 Years Warranty



30-60W



80-120W



130-200W

LD331 LED STREET LIGHT

Plusrite®

LIGHT DISTRIBUTION

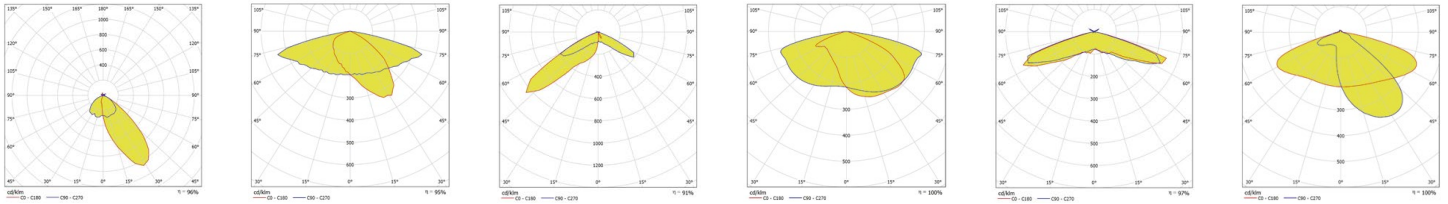

DIMENSIONS

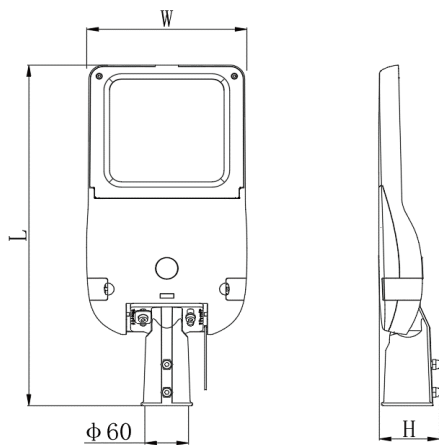

APPLICATION



@ 2025 Plusrite All rights reserved. Plusrite does not give any representation or warranty as to the accuracy or completeness of the information included herein and shall not be liable for any action in reliance thereon. The information presented in this document is not intended as any commercial offer and does not form part of any quotation or contract, unless otherwise agreed by Plusrite.



Contact Us



Official WeChat

PLUSRITE ELECTRIC (CHINA) CO., LTD

27 Teng Long Road, Wujin District, Changzhou Jiangsu, 213149 China
www.plusrite.com / info@pluslight.com